

Energizer®



4 IN 1 CORDLESS SCREWDRIVER

EZT4V41IN1

USER GUIDE

CAUTION: Read this manual before using this machine!

Energizer®

©2024 Energizer. Energizer and certain graphic designs are trademarks of Energizer Brands, LLC and related subsidiaries and are used under license by Builder SAS. All other brand names are trademarks of their respective owners. Neither Builder SAS nor Energizer Brands, LLC is affiliated with the respective owners of their trademarks.

Let's get started.

You're excited to power up, so we'll keep this brief!

CONTENTS

1. INTENDED USE.....	5
2. SAFETY INSTRUCTIONS.....	5
3. YOUR PRODUCT.....	9
4. PACKAGE CONTENTS.....	10
5. TECHNICAL DATA.....	10
6. BEFORE USE.....	11
7. ASSEMBLE THE ATTACHMENTS.....	12
8. OPERATION.....	14
9. MAINTENANCE, STORAGE AND CLEANING.....	14
10. DISPOSAL.....	14
11. DELARATION OF CONFORMITY.....	15
12. WARRANTY.....	16
13. PRODUCT FAILURE.....	17
14. WARRANTY EXCLUSIONS.....	18

1. INTENDED USE

This appliance is designed for screwing into wood, plastic and metal. The cutting attachment is designed exclusively for cutting soft materials, such as card and similar materials up to a thickness of 6 mm. Use this product only as described and for the areas of applications specified. The appliance is not intended for commercial use. Any other usage or modification of the appliance is deemed to be improper and carries a significant risk of accidents. The manufacturer accepts no responsibility for damage(s) attributable to misuse.

2. SAFETY INSTRUCTIONS

GENERAL POWER TOOL SAFETY WARNINGS



WARNING: Read all safety warnings, instructions, illustrations and specifications provided with this power tool. *Failure to follow all instructions listed below may result in electric shock, fire and/or serious injury.*

Save all warnings and instructions for future reference.

The term "power tool" in the warnings refers to your mains-operated (corded) power tool or battery-operated (cordless) power tool.

1) Work area safety

- a) **Keep work area clean and well lit.** *Cluttered or dark areas invite accidents.*
- b) **Do not operate power tools in explosive atmospheres, such as in the presence of flammable liquids, gases or dust.** *Power tools create sparks which may ignite the dust or fumes.*
- c) **Keep children and bystanders away while operating a power tool.** *Distractions can cause you to lose control.*

2) Electrical safety

- a) **Power tool plugs must match the outlet. Never modify the plug in any way. Do not use any adapterplugs with earthed (grounded) power tools.** *Unmodified plugs and matching outlets will reduce risk of electric shock.*
- b) **Avoid body contact with earthed or grounded surfaces, such as pipes, radiators, ranges and refrigerators.** *There is an increased risk of electric shock if your body is earthed or grounded.*
- c) **Do not expose power tools to rain or wet conditions.** *Water entering a power tool will increase the risk of electric shock.*
- d) **Do not abuse the cord. Never use the cord for carrying, pulling or unplugging the power tool. Keep cord away from heat, oil, sharp edges or moving parts.** *Damaged or entangled cords increase the risk of electric shock.*
- e) **When operating a power tool outdoors, use an extension cord suitable for outdoor use.** *Use of a cord suitable for outdoor use reduces the risk of electric shock.*
- f) **If operating a power tool in a damp location is unavoidable, use a residual current device (RCD) protected supply.** *Use of an RCD reduces the risk of electric shock.*

3) Personal safety

- a) **Stay alert, watch what you are doing and use common sense when operating a power tool. Do not use a power tool while you are tired or under the influence of drugs,**

alcohol or medication. *A moment of inattention while operating power tools may result in serious personal injury.*

- b) Use personal protective equipment. Always wear eye protection.** *Protective equipment such as a dust mask, non-skid safety shoes, hard hat or hearing protection used for appropriate conditions will reduce personal injuries.*
- c) Prevent unintentional starting. Ensure the switch is in the off-position before connecting to a power source and/or battery pack, picking up or carrying the tool.** *Carrying power tools with your finger on the switch or energising power tools that have the switch on invites accidents.*
- d) Remove any adjusting key or wrench before turning the power tool on.** *A wrench or a key left attached to a rotating part of the power tool may result in personal injury.*
- e) Do not overreach. Keep proper footing and balance at all times.** *This enables better control of the power tool in unexpected situations.*
- f) Dress properly. Do not wear loose clothing or jewelry. Keep your hair and clothing away from moving parts.** *Loose clothes, jewelry or long hair can be caught in moving parts.*
- g) If devices are provided for the connection of dust extraction and collection facilities, ensure these are connected and properly used.** *Use of dust collection can reduce dust-related hazards.*
- h) Do not let familiarity gained from frequent use of tools allow you to become complacent and ignore tool safety principles.** *A careless action can cause severe injury within a fraction of a second.*

4) Power tool use and care

- a) Do not force the power tool. Use the correct power tool for your application.** *The correct power tool will do the job better and safer at the rate for which it was designed.*
- b) Do not use the power tool if the switch does not turn it on and off.** *Any power tool that cannot be controlled with the switch is dangerous and must be repaired.*
- c) Disconnect the plug from the power source and/or remove the battery pack, if detachable, from the power tool before making any adjustments, changing accessories, or storing power tools.** *Such preventive safety measures reduce the risk of starting the power tool accidentally.*
- d) Store idle power tools out of the reach of children and do not allow persons unfamiliar with the power tool or these instructions to operate the power tool.** *Power tools are dangerous in the hands of untrained users.*
- e) Maintain power tools and accessories. Check for misalignment or binding of moving parts, breakage of parts and any other condition that may affect the power tool's operation. If damaged, have the power tool repaired before use.** *Many accidents are caused by poorly maintained power tools.*
- f) Keep cutting tools sharp and clean.** *Properly maintained cutting tools with sharp cutting edges are less likely to bind and are easier to control.*
- g) Use the power tool, accessories and tool bits etc. In accordance with these instructions, taking into account the working conditions and the work to be performed.** *Use of the power tool for operations different from those intended could result in a hazardous situation.*
- h) Keep handles and grasping surfaces dry, clean and free from oil and grease.** *Slippery*

handles and grasping surfaces do not allow for safe handling and control of the tool in unexpected situations.

5) Battery tool use and care

- a) **Recharge only with the charger specified by the manufacturer.** *A charger that is suitable for one type of battery pack may create a risk of fire when used with another battery pack.*
- b) **Use power tools only with specifically designated battery packs.** *Use of any other battery packs may create a risk of injury and fire.*
- c) **When the battery pack is not in use, keep it away from other metal objects, like paper clips, coins, keys, nails, screws or other small metal objects, that can make a connection from one terminal to another.** *Shorting the battery terminals together may cause burns or a fire.*
- d) **Under abusive conditions, liquid may be ejected from the battery; avoid contact. If contact accidentally occurs, flush with water. If liquid contacts eyes, additionally seek medical help.** *Liquid ejected from the battery may cause irritation or burns.*
- e) **Do not use a battery pack or tool that is damaged or modified.** *Damaged or modified batteries may exhibit unpredictable behaviour resulting in fire, explosion or risk of injury.*
- f) **Do not expose a battery pack or tool to fire or excessive temperature.** *Exposure to fire or temperature above 130°C may cause explosion.*
- g) **Follow all charging instructions and do not charge the battery pack or tool outside the temperature range specified in the instructions.** *Charging improperly or at temperatures outside the specified range may damage the battery and increase the risk of fire.*

6) Service

- a) **Have your power tool serviced by a qualified repair person using only identical replacement parts.** *This will ensure that the safety of the power tool is maintained.*
- b) **Never service damaged battery packs.** *Service of battery packs should only be performed by the manufacturer or authorized service providers.*
- c) **Hold the power tool by insulated gripping surfaces, when performing an operation where the cutting accessory may contact hidden wiring.** *Cutting accessory contacting a "live" wire may make exposed metal parts of the power tool "live" and could give the operator an electric shock.*

7) ELECTRICAL SAFETY

- a) Connect the charger only to a 100-240V~ socket.
- b) Load the battery of the screwdriver only with the appropriate charger.
- c) The charger and screwdriver must be protected against moisture!
- d) Do not use the charger outdoors.
- e) In order to protect the batteries from damage, never expose them to temperatures above 50 °C.
- f) Warning: Do not short-circuit the battery or charger contacts.
- g) Repeat positive and negative polarity when recharging the battery.
- h) Do not throw the battery into the fire.



8) ADDITIONAL INSTRUCTIONS FOR CHARGER

- **Use the charger provided with the tool only to charge the battery.**

- Never attempt to charge non-rechargeable batteries.
- Have defective cords replaced immediately.
- Do not expose to water.
- Do not open the charger.
- Do not probe the charger.
- The charger is intended for indoor use only.
- This charger can be used by children aged from 8 years and above and persons with reduced physical, sensory or mental capabilities or lack of experience and knowledge if they have been given supervision or instruction concerning use of the appliance in a safe way and understand the hazards involved.
- Children shall not play with the appliance. Cleaning and user maintenance shall not be made by children without supervision.
- If the supply cord is damaged, it must be replaced by the manufacturer, its service agent or similarly qualified persons in order to avoid a hazard.

⚠ CAUTION: Do not recharge non-rechargeable batteries.

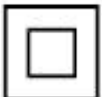
9)SYMBOLS

	To reduce the risk of injury, the user must read and understand this manual before using this product.
	Class II, double isolation(only for charger).
	Use the battery and charger Indoor use only.
	Conforms to relevant safety standards.



Do not dispose of old appliances with domestic rubbish.

3. YOUR PRODUCT

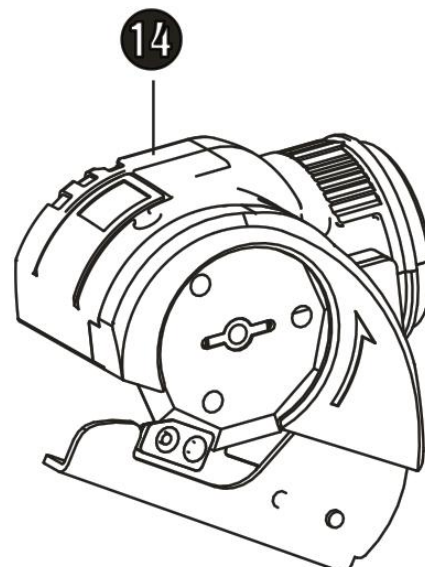
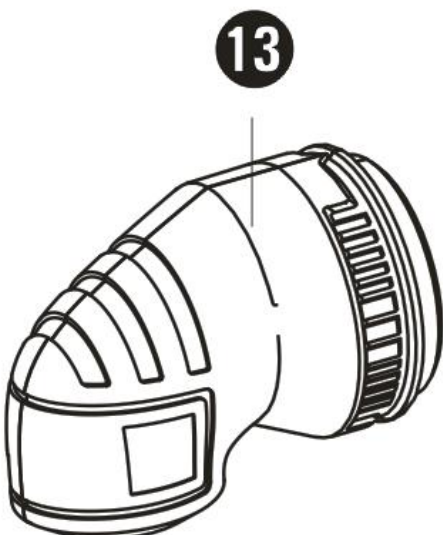
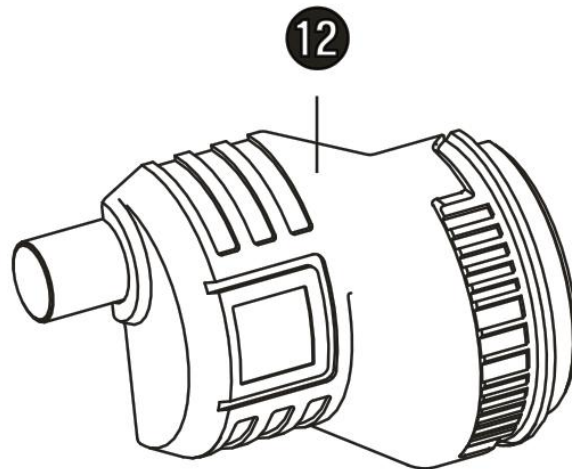
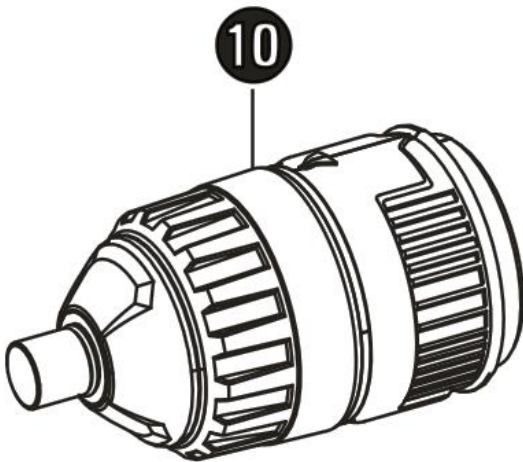
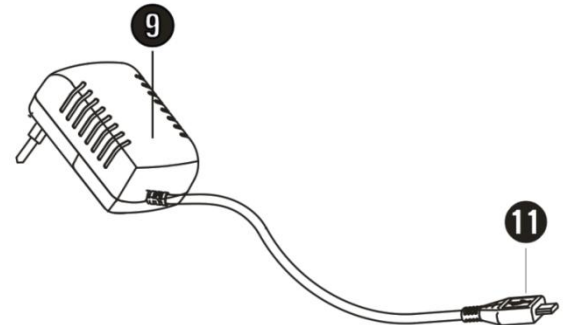
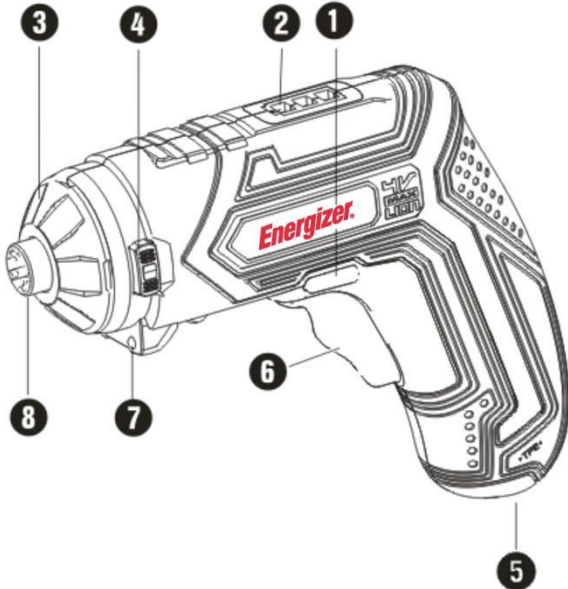

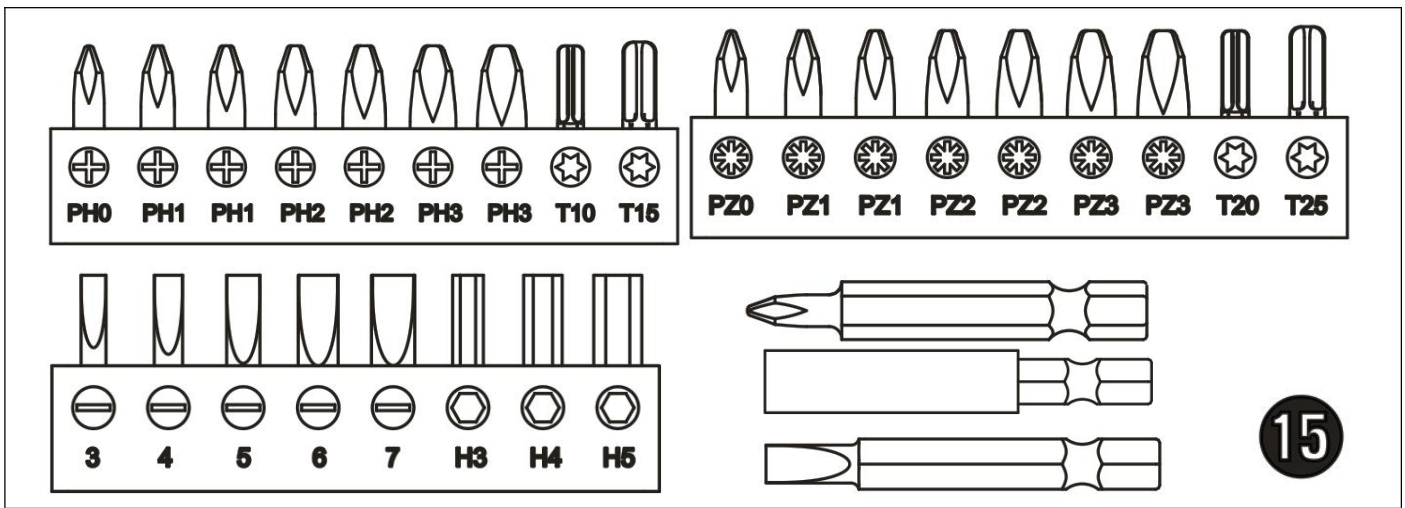

1	Rotation direction switch /safety lock-out	6	ON/OFF switch	11	Micro USB plug of the charging cable
2	Battery charge level indicator	7	LED lamps	12	Eccentric attachment
3	Rubber cap	8	Tool holder	13	Angle attachment
4	Lock bottom	9	Charger	14	Cutting attachment
5	Charging socket	10	Torque attachment	15	Bits and bit extension

4. PACKAGE CONTENTS

1 Cordless screwdriver	2 Bits x 50 mm	1 Angle attachment
1 Charger	1 Bit extension	1 Cutting attachment
1 BMC	1 Torque attachment	1 Set of operating instructions
26 Bits x 25mm	1 Eccentric attachment	1 Charging cable

5. TECHNICAL DATA

Model	EZT4V4IN1
Voltage	4.0 V d.c.
Battery cell	INR18650E Li-ion
Battery capacity	1500mAh
No-load speed	200/min
Torque	4.0Nm (max)
Charger	EZT4V4IN1
Charge time	1.0h
Charger in put	100-240V~, 50/60Hz, 0.3A max
Charger output	5.5 V d.c., 1750mA
Charger Protection class	II / (double insulation)
Weight	Approx 0.5Kg
Sound pressure level	LPA: 66.2dB(A) k=3.0dB(A)
Sound power level	LWA: 77.2dB(A) k=3.0dB(A)
Vibration emission value	Ah: 0.8m/s ² k=1.5m/s ²

The vibration value of does not exceed 2.5m/s²

INFORMATION

- The declared vibration total value(s) and the declared noise emission value(s) have been measured in accordance with a standard test method and may be used for comparing one tool with another.
- The declared vibration total value(s) and the declared noise emission value(s) may also be used in a preliminary assessment of exposure.

WARNING:

- The vibration and noise emissions during actual use of the power tool can differ from the declared values depending on the ways in which the tool is used especially what kind of workpiece is processed.
- Identify safety measures to protect the operator that are based on an estimation of exposure in the actual conditions of use (taking account of all parts of the operating cycle such as the times when the tool is switched off and when it is running idle in addition to the trigger time).
- Wear hearing protection.

6. BEFORE USE

6.1 Charging the appliance battery (see fig. a)

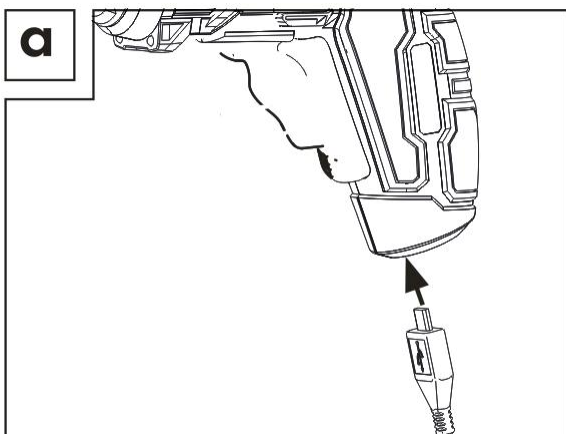

NOTE:

- The battery is supplied partially charged. Before first use, charge the battery in the charger for at least 1 hour. This guarantees full battery power. Li-ion batteries can be charged at any time without adversely affecting their service life. Interruption of the charging process will not damage the battery.
- If the battery charge level indicator lights up red during use, the battery is at less than 30% of its capacity and needs to be charged.
- Never charge the cordless appliance when the ambient temperature is below 10°C or above 40°C. If a lithium-ion battery is to be stored for an extended period, the charge level should be checked regularly. The optimum charge level is between 50% and 80%. The storage climate should be cool and dry and the ambient temperature should be between 0°C and 50°C.

6.2 Start charging

- Connect the charger to a 100–240 V~ 50/60 Hz power source.
- The battery is fully charged when the battery level display changes from red to green.

6.3 Stopping charging

- Disconnect the charger from the mains power supply.

7. ASSEMBLE THE ATTACHMENTS

7.1 Usage

- With the torque attachment screwing stops as soon as the screw is tight. Set the required torque from one of the 10 levels.
- The eccentric attachment allows you to screw even in locations that are close to the wall.
- The angle attachment allows you to screw at right angles.
- The cutting attachment allows you to cut soft materials, such as card and similar materials up to a thickness of 6 mm.

7.2 Assembly

NOTE:

- Before carrying out any work on the appliance, ensure that the rotation direction switch is in the middle. This prevents unintentional switching on.
- Start by removing the rubber cap from the tool holder (see fig. b).

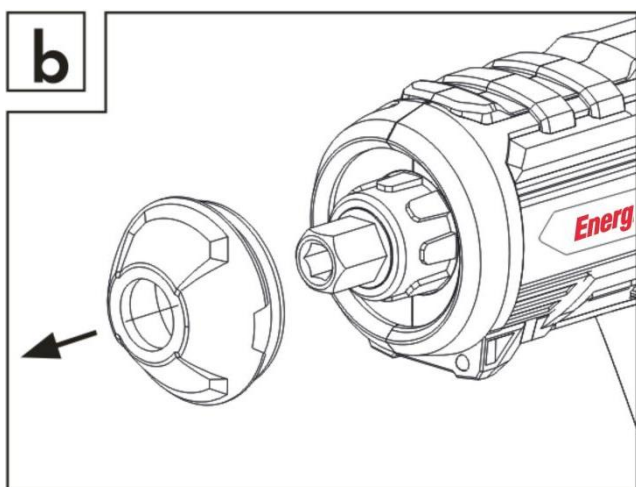

- Now you can fit the supplied attachments to the appliance in 45° steps. Fit the attachment onto the appliance so that the attachment clicks into place. (See fig. C, example: torque attachment).

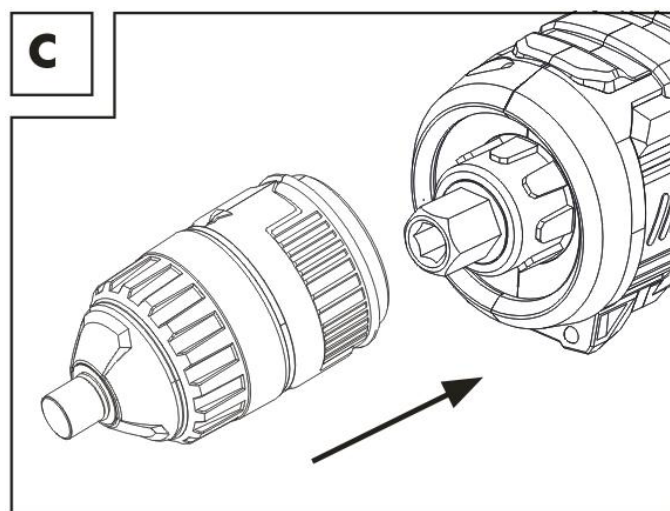

7.3 Dismantling

- To remove the attachments from the appliance, press the release button and pull the attachment forwards.
- Afterwards, replace the rubber cap on the tool holder.

7.4 Changing bits/screw driver bits (see fig. d)

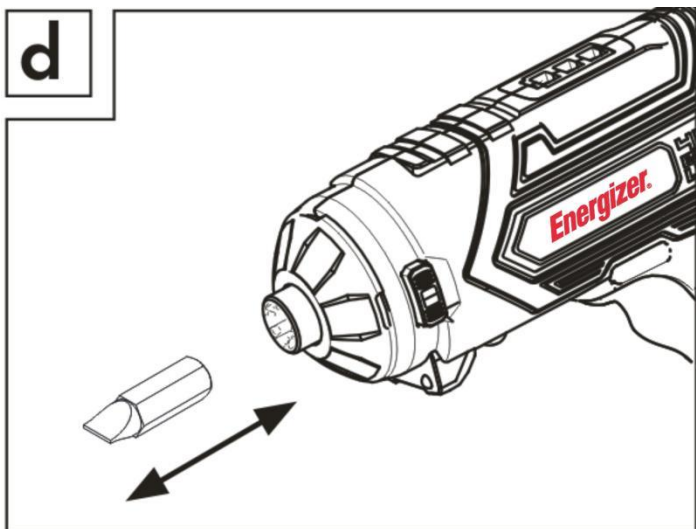

Inserting:

- Insert the bit into the tool holder.

Removal:

- Pull the bit out of the tool holder.

7.5 Replacing the cutting blade (see fig. e + f)

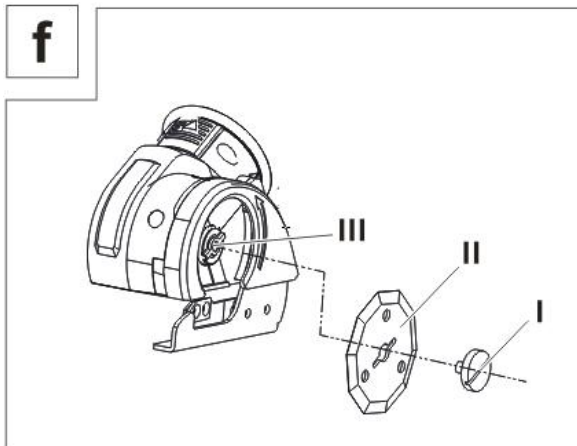
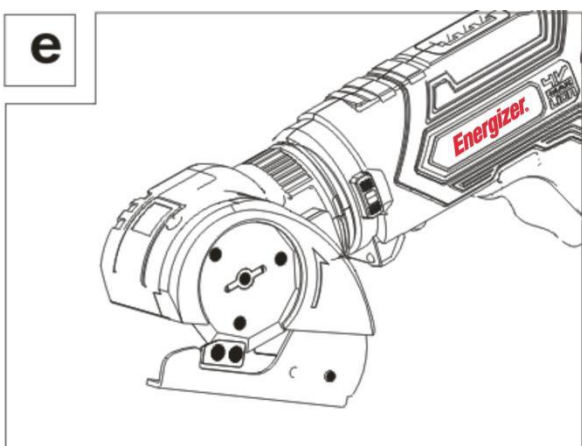

NOTE:

- Before carrying out any work on the appliance, ensure that the rotation direction switch is in the middle. This prevents unintentional switching on.
- Start by connecting the cutting attachment to the appliance. This blocks the motor spindle and allows the screw to be removed.
- Unscrew the screw (I).
- Remove the cutting blade (II) by pulling it downwards.
- Push in a new cutting blade (II) from below ensuring that the ground edge of the blade faces you. Turn around the blade (II) until it fits onto the tool fitting (III).
- Tighten the screw (I).
- The attachment can now be used again.

CAUTION!

- There is an arrow () on the blade guard of the cutting attachment. This shows you the recommended running direction of the cutting blade.

8. OPERATION

8.1 Switching the cordless screwdriver ON/OFF

Switching on:

- To start the appliance, press the ON/OFF switch and keep it pressed in.

Switching off:

- Release the ON/OFF switch to switch off the appliance.

8.2 Changing the direction of rotation

Clockwise:

- Push the rotation direction switch to the left.
- Press the ON/OFF switch, the clockwise rotation; you can now screw in the screws.

Anti-clockwise:

- Push the rotation direction switch to the right.
- Press the ON/OFF switch, the anticlockwise rotation; you can now unscrew the screws.

Safety lock-out:

- Push the rotation direction switch into the middle position. The ON/OFF switch is blocked.

NOTE:

- When the ON/OFF switch is locked it is still possible to activate the LED lamps. To do this, press the ON/OFF switch.

8.3 Tips and tricks

Screw bits are labeled according to their dimensions and their shape. If you are unsure, always try the particular screw bit out to see whether it sits in the screw head without any free play.

9. MAINTENANCE, STORAGE AND CLEANING



WARNING!

RISK OF ELECTRIC SHOCK! Before cleaning, disconnect the charger from the mains socket.

- Before carrying out any work on the appliance, ensure that the rotation direction switch is in the middle. This prevents unintentional switching on.
- The cordless screwdriver is maintenance-free.
- The appliance must always be kept clean, dry and free from oil or grease.
- Never allow liquids to get into the appliance.
- Use a cloth to clean the housing. Never use petrol, solvents or cleansers which can damage plastic.



WARNING!

- Remove the attachments before cleaning. Clean them with a dry cloth.
- Always ensure the appliance and attachments are clean, free of dust and dry before storing.

10. DISPOSAL



The packaging is made from environmentally friendly material and can be disposed of at your local recycling plant.



Electric power tools, as well as their accessories and packaging, must each be able to follow an appropriate recycling pathway. Only for the countries of the European Union:

Do not throw away your electrical appliance with the household waste! In accordance with the European Directive 2012/19/EU on waste electrical and electronic equipment and its implementation in national laws, power tools that can no longer be used must be separated and follow an appropriate recycling pathway.



Li-ion

Do not dispose of batteries in your normal household waste!

11. DELARATION OF CONFORMITY



BUILDER SAS

ZI, 32 rue Aristide Bergès- 31270 Cugnaux-France

Tel : + 33 (0) 5.34.502.502 Fax : + 33 (0) 5.34.502.503

Declares that the machinery designated below:

Cordless screwdriver

EZT4V4IN1

Serial number: 20240605206-20240605705

Complies with the provisions of the Directive « machinery » 2006/42/EC and national laws transposing it:

Also complies with the following European directives:

EMC DIRECTIVE: 2014/30/EU

RoHS DIRECTIVE: 2011/65/EU & (EU) 2015/863

Also complies with European standards, with national standards and the following technical provisions:

EN62841-1: 2015

EN62841-2-2: 2014; EN ISO12100: 2010

EN IEC55014-1: 2021

EN IEC55014-2: 2021

EN 62233:2008

EN 60335-2-29:2021/A1:2021

EN 60335-1: 2012/A15:2021

EN IEC61000-3-2:2019/A1:2021; EN 61000-3-3:2013/A1:2019

EN IEC61000-6-1:2019; EN IEC61000-6-3:2021

Responsible for the technical file: Mr. Olivier Patriarca

Done at Cugnaux, le 11/05/2024

Philippe Marie/PDG

12. WARRANTY

Energizer[®]

WARRANTY

The manufacturer guarantees the product against defects in material and workmanship for a period of 2 years from the date of the original purchase. The warranty only applies if the product is for household use. The warranty does not cover breakdowns due to normal wear and tear.

The manufacturer agrees to replace parts identified as defective by the designated distributor. The manufacturer does not accept responsibility for the replacement of the machine, in whole or in part, and/or ensuing damage.

The warranty does not cover breakdowns due to:

- insufficient maintenance.
- abnormal assembly, adjustment or operations of the product.
- parts subject to normal wear and tear.

The warranty does not extend to:

- shipping and packaging costs.
- using the tool for a purpose other than that for which it was designed.
- the use and maintenance of the machine done in a manner not described in the user manual.

Due to our policy of continuous product improvement, we reserve the right to alter or change specifications without notice. Consequently, the product may be different from the information contained therein, but a modification will be undertaken without notice if it is recognized as an improvement of the preceding characteristic.

READ THE MANUAL CAREFULLY BEFORE USING THE MACHINE.

When ordering spare parts, please indicate the part number or code, you can find this in the spare parts list in this manual. Keep the purchase receipt; without it, the warranty is invalid. To help you with your product, we invite you to contact us by phone or via our website:

- **+33 (0)9.70.75.30.30**
- **<https://services.swap-europe.com/contact>**

You must create a "ticket" via the web platform.

- Register or create your account.
- Indicate the reference of the tool.
- Choose the subject of your request.
- Describe your problem.
- Attach these files: invoice or sales receipt, photo of the identification plate (serial number), photo of the part you need (for example: pins on the transformer plug which are broken).



13. PRODUCT FAILURE

WHAT TO DO IF MY MACHINE BREAKS DOWN?

If you bought your product in a store:

- a) Empty the fuel tank if your product has one.
- b) Make sure that your machine is complete with all accessories supplied, and clean! If this is not the case, the repairer will refuse the machine.

Go to the store with the complete machine and with the receipt or invoice.

If you bought your product on a website:

- a) Empty the fuel tank if your product has one.
- b) Make sure that your machine is complete with all accessories supplied, and clean! If this is not the case, the repairer will refuse the machine.
- c) Create a SWAP-Europe service ticket on the site: <https://services.swap-europe.com>. When making the request on SWAP-Europe, you must attach the invoice and the photo of the nameplate (serial number).
- d) Contact the repair station to make sure it is available before dropping off the machine.

Go to the repair station with the complete machine packed, accompanied by the purchase invoice and the station support sheet downloadable after the service request is completed on the SWAP-Europe site.

For machines with engine failure from manufacturers BRIGGS & STRATTON, HONDA and RATO, please refer to the following instructions.

Repairs will be done by approved engine manufacturers of these manufacturers, see their site:

- <http://www.briggsandstratton.com/eu/fr>
- <http://www.honda-engines-eu.com/fr/service-network-page;jsessionid=5EE8456CF39CD572AA2AEEDFD290CDAE>
- <https://www.rato-europe.com/it/service-network>

Please keep your original packaging to allow for after-sales service returns or pack your machine with a similar cardboard box of the same dimensions.

For any question concerning our after-sales service you can make a request on our website <https://services.swap-europe.com>

Our hotline remains available at +33 (9) 70 75 30 30.



14. WARRANTY EXCLUSIONS

THE WARRANTY DOES NOT COVER:

- Start-up and setting up of the product.
- Damage resulting from normal wear and tear of the product.
- Damage resulting from improper use of the product.
- Damage resulting from assembly or start-up not in accordance with the user manual.
- Breakdowns related to carburetion beyond 90 days and fouling of carburetors.
- Periodic and standard maintenance events.
- Actions of modification and dismantling that directly void the warranty.
- Products whose original authentication marking (brand, serial number) has been degraded, altered or withdrawn.
- Replacement of consumables.
- The use of non-original parts.
- Breakage of parts following impacts or projections.
- Accessories breakdowns.
- Defects and their consequences linked to any external cause.
- Loss of components and loss due to insufficient screwing.
- Cutting components and any damage related to the loosening of parts.
- Overload or overheating.
- Poor power supply quality: faulty voltage, voltage error, etc.
- Damages resulting from the deprivation of enjoyment of the product during the time necessary for repairs and more generally the costs related to the immobilization of the product.
- The costs of a second opinion established by a third party following an estimate by a SWAP-Europe repair station.
- The use of a product which would show a defect or a breakage which was not the subject of an immediate report and/or repair with the services of SWAP-Europe.
- Deterioration linked to transport and storage*.
- Launchers beyond 90 days.
- Oil, petrol, grease.
- Damages related to the use of non-compliant fuels or lubricants.

* In accordance with transport legislation, damage related to transport must be declared to carriers within 48 hours maximum after observation by registered letter with acknowledgement of receipt.

This document is a supplement to your notice, a non-exhaustive list.

Attention: All orders must be checked in the presence of the delivery person. In case of refusal by the delivery person, you must simply refuse the delivery and notify your refusal.

Reminder: The reserves do not exclude the notification by registered letter with acknowledgement within 72 hours.

Information: Thermal devices must be wintered each season (service available on the SWAP-Europe site). Batteries must be charged before being stored.

Energizer®